

Charge Excitations

In the previous lectures we discussed the neutral excitations of singlet and triplet excitons. We now move to discuss the electron (negatively charged) or hole (positively charged) excitation. After reminding ourselves of the charge-polaron concept we will first discuss the excitation paths that result in charges and second the motion of these charges and processes they undergo (as recombination).

Charge Polarons

At this stage we should remind ourselves that the molecules (polymers etc) tend to react to the presence of an excited state by changing its (co-ordinate) configuration. In this field we encounter terms of hole/electron, ionised molecule (specie), polaron. All of these are correct given the right context.

When we have a charge (electron/hole) in the system its localised nature dictates that it has to reside on a given chain (molecule)^a. In this case we have a molecule containing the charge and hence we can refer to it as an ionic specie. We also know that the charge will couple to (sometimes distort) the physical shape of the molecule (and change its electronic states) and hence we can also refer to it as a charge-polaron or polaron (remember that polaron = charge + lattice distortion). The distortion due to the presence of a charge sometimes tends to change the electronic states **in the charge vicinity** so that the highest occupied molecular level (HOMO) shifts upward and the lowest unoccupied level (LUMO) shifts downward in that region. Namely the distortion results in a reduction in the ionisation potential. This is very different to the case of inorganic semiconductors as depicted in Figure 1. Sometimes, and especially in chemistry originating texts, the polaron is simply a charge coupled to the molecular vibrations so that they are one entity (there is no explicit need for any change in the configuration co-ordinates picture).

^a In special cases the polaron wavefunction may spread across a few chains [1, 2]

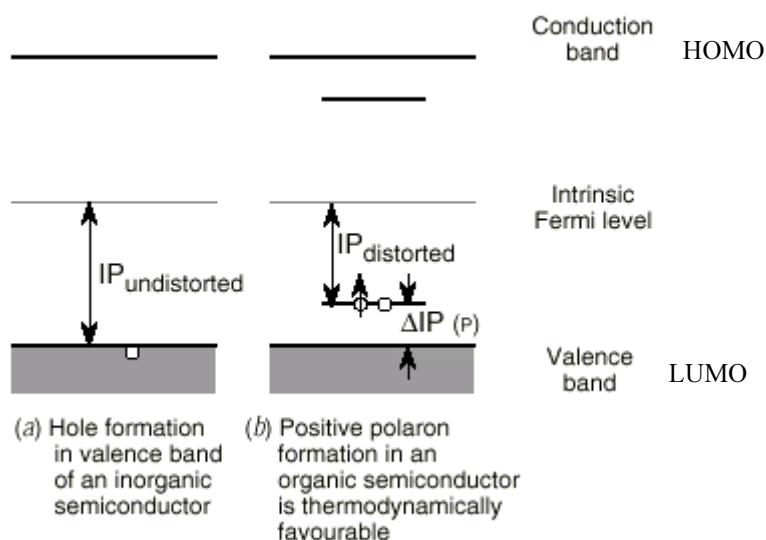

Figure 1. The distorted geometry of the excited state (lattice relaxation) results in a reduction of the ionisation potential, ΔIP (a) and hence the accommodation of charge within two 'polaron' states within the semiconductor gap (b).

In Figure 1 the levels in the midgap are the new levels of the distorted region as described above. They are effectively added to the undistorted states described here as the HOMO and LUMO. The formation of these distorted levels is favourable since it gives rise to an overall reduction in energy or in other words there is a "binding energy" associated with the formation of a polaron. At this stage it is important to mention that there could also be a bi-polaron being formed. Again it is a radical ion, but doubly charged). Since it consists of two opposite spins the total spin is zero. It is not clear if these species are stable at normal operation conditions or are effectively stabilised by defects (when these are present).

As a reminder we show in Figure 2 a distortion associated with the formation of either polaron or bi-polaron.

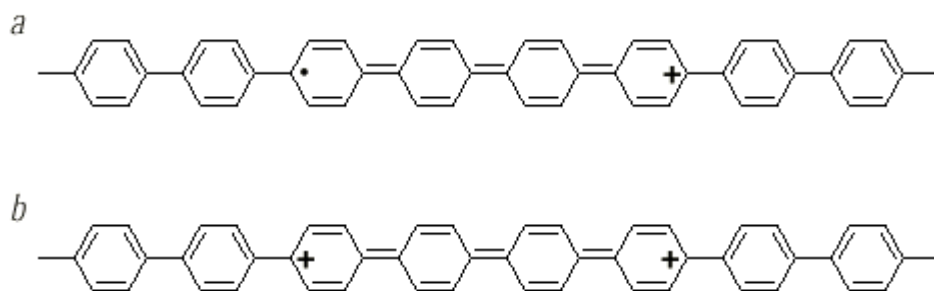

Figure 2. A geometric representation of: (a) a singly charged polaron [radical ion coupled to a lattice distortion], having spin $1/2$, charge $\pm e$ and (b) a doubly charged bipolaron [spinless di-ion coupled to a lattice distortion], having spin 0 and charge $\pm 2e$.

Charge Generation via Exciton dissociation

There could be several sources for charge generation in organic materials. The first one is the dissociation of excitons. We already saw that by combining positive and negative excitations a neutral exciton is formed and what we suggest here is the reverse process:

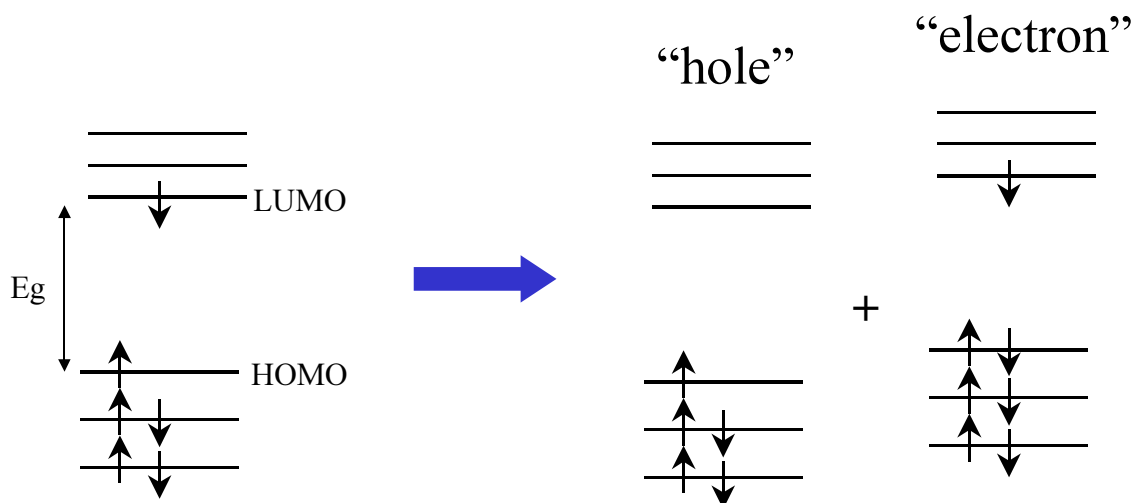

Figure 3. Schematic description of the exciton dissociation into a positive and negative excitations.

This process of charge generation via exciton dissociation is often referred to in the context of photo-cells. Namely, when an exciton is generated by optical means and then is broken by the physical structure into charges to generate current or voltage. The second context is in light emitting devices when one is concerned whether the voltage (field) used to inject charges and create excitons will actually dissociate the excitons and effectively prevent their formation and light emission (field induced quenching). The third context is the debate over what is really created once a photon is absorbed. Do we create excitons, charges, a mixture of the two etc.

"Spontaneous" or Structural Dissociation

By spontaneous we mean that no external force is imposed upon the organic material (or materials) to promote dissociation. If it is a spontaneous process then it is clear that the final state of two separated charges should be energetically favoured with respect to the exciton-state. To discuss this topic we need to step through a "minefield" of arguments regarding the exciton energetics, its so-called binding energy etc. I hope to find the right path here but if you are enthusiastic then by running a search for "exciton" and author names of "R.H. Friend" and "A.J. Heeger" you are bound to find relevant discussions and references to others (note that the definition of an exciton and its so called binding energy may vary between papers/authors). I wish to remind you that the definition for an exciton, as we used in the previous lectures (following Feynman), does not regard the issue of binding energy to be so important for the exciton to be proud of its name.

Let us first consider a relaxed exciton or the first excited state. Once an exciton is formed it may diffuse towards an interface where it may be blocked [3, 4], transferred to the next layer [5], or even be dissociated [6-8]. The parameter governing the outcome is the **formation** energy of an exciton on the two sides of the interface as well as the energy levels alignment at the interface. The conceptual description of the formation energy, in a molecular picture, is shown in Figure 4 [9].

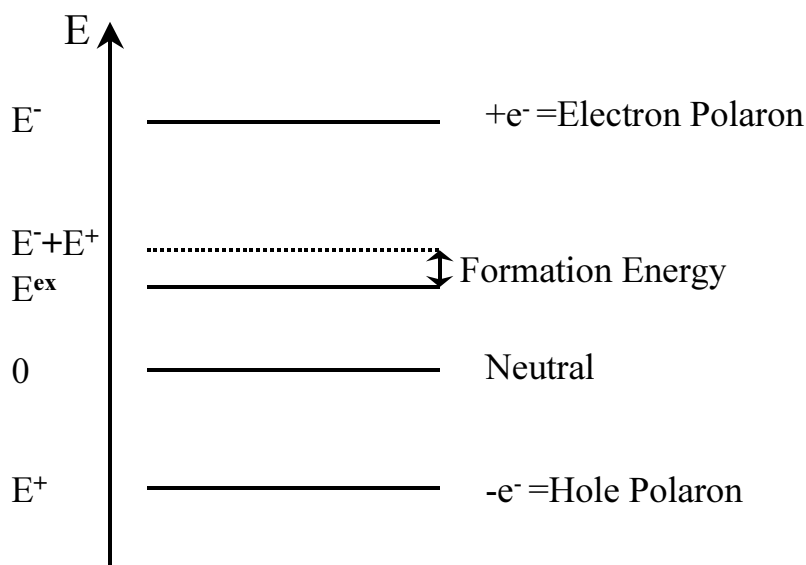

Figure 4. Schematic description of the energy of a molecule in its neutral state and first positive (hole), negative (electron), and exciton states. The formation energy is shown as the decrease in the molecule energy after correlating separated electron and hole to form an exciton

Another way of defining the formation energy (sometimes loosely called "binding") is to compare the intrachain exciton (the one we discussed so far) to an interchain exciton. The interchain exciton consists of two charges residing on different chains but still are correlated (can move together \rightarrow exciton). The motivation to use such a criteria is the assumption (often justified) that the interchain exciton can easily dissociate into non-correlated charge-polaron. Or in other words, the formation energy of the interchain exciton is on the order of kT (however Rothberg has reported stable interchain polaron pairs [10]).

As we will see, it is possible to predict if an exciton will dissociate based on the energy levels (HOMO/LUMO) in the two relevant chains as well as the energy of the first excited intrachain exciton state [8]. To do so one needs to invoke a "magic" number which states the energy penalty needed to go from intrachain to interchain exciton where all chains are identical. This number was taken to be 0.35eV and is reasonably close to the experimentally estimated formation energy of the intrachain exciton.

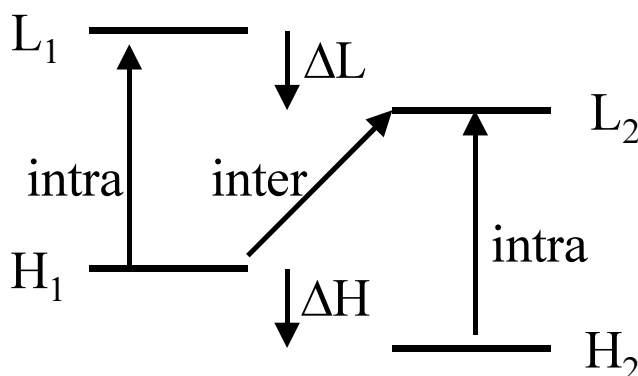

Figure 5. Schematic description of the energy levels (HOMO/LUMO)^b at the interface between two materials and the possible formation of the interchain exciton.

If we define $\Delta L = L_1 - L_2$ and $\Delta H = H_1 - H_2$ and both are positive then a charge transfer and a formation of interchain exciton is possible. If the exciton is produced on chain 1 then the interchain exciton level will be stabilised by ΔL due to the transfer of the electron to a lower state. If we also account for the energy needed to get there then the position of the interchain exciton level with respect to the intrachain exciton in chain 1 is ($\Delta L' = \Delta L - 0.35\text{eV}$) below it. If we start on chain 2 then it will be ($\Delta H' = \Delta H - 0.35\text{eV}$) below the intrachain-exciton in chain 2. The final situation can be either of the two depicted in Figure 6. The left side represents exciton-dissociation scenario and the right side an energy-transfer scenario.

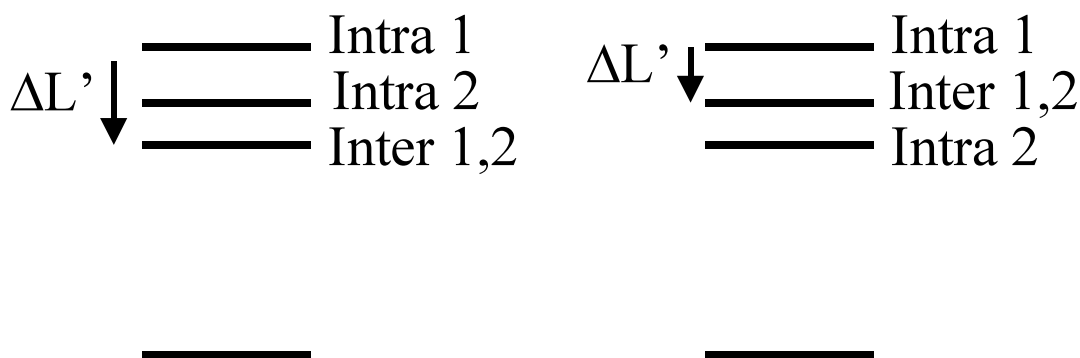

Figure 6. Schemes of energy level alignment. Left, formation of interchain exciton is favourable. Right, energy transfer to the other material is favourable.

^b How would you deduce the position experimentally? Cyclic Voltametry, CV+absorption, CV+emission, LED+LEC configuration, stm meas....

Comment: *The issue of "binding" energy is often confusing in the molecular electronic field simply because most people think of an exciton as the specie found in basic (inorganic) semiconductor textbooks. The exciton in bulk inorganic semiconductor where the only force that can keep electron and hole close to each other is their mutual coulomb attraction. In molecular materials (incl. inorganic quantum dots) the electron and hole are confined in space largely due to the potential imposed by the molecule (walls of the dot if you like). The safest way to avoid the confusion in this case might be to name them electron-hole pairs [11] and thus differentiate them from the "textbook" bulk excitons.*

For example, in ref [12] they report an experiment where the size of the electron-hole pair is measured as a function of the molecule size (as dot size). They found that the size of the pair scales with the molecular size and hence the "binding" in its common definition (coulomb binding) has negligible effect on its size. This of course does not mean that to dissociate the pair (extract a charge from the dot) won't cost energy. Namely, one can have dissociation energy with negligible (coulomb) "binding." If you are planning to read this paper note that the size measured is probably before structural relaxation (before the exciton becomes exciton-polaron). Such relaxation may reduce its size and enhance the dissociation energy but these fine details (as well as the possibility that for large enough molecules, or conjugation lengths, there won't be excitons without structural relaxation) are beyond this (too long) comment.

Charge Generation via high energy excitation

It has been shown by Köhler et. al. that the higher excited state of the exciton has a significant delocalised character (high separation between electrons and holes). Namely when one excites the polymer with a high energy photon the result may be that of charges which dissociated from the high energy exciton state. Naturally, the dissociation needs to be fast before the excited state relaxes to the ground exciton state. In this case it is a bit semantic whether the optical beam has formed charges directly or it was via "extremely" short-lived exciton-state. Resonance to other excitation manifolds (triplet, interchain, ..) may be important as well.

Charge Generation via thermal processes

The typical bandgap of the polymers we are concerned with here are of 2eV or more. In most cases we deal with undoped polymers and hence the Fermi level is about 1eV from the HOMO/LUMO and hence no thermal generation is expected. Sometime one may find unintentional doping and the related thermally released charges. The density would depend on the material and in well prepared polymers one would expect it to be below $1e15\text{cm}^{-3}$.

Charge Generation via current injection

As we have seen in the first lecture, the position of the energy levels of either the HOMO or the LUMO may vary significantly and hence the energy difference between either the HOMO or the LUMO and the work function of a given contact material may vary as well. Hence, in general there exists a barrier to charge injection as is schematically shown in Figure 7.

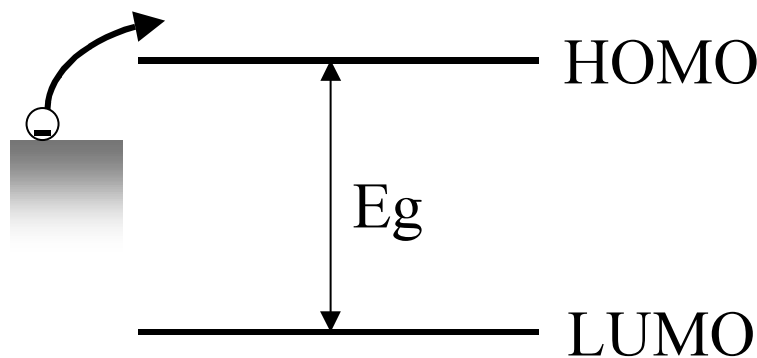

Figure 7. Conceptual description of the barrier between an injecting material and a semiconducting polymer.

When the contact material is of metallic nature one often finds the known Richardson-Schottky barrier formalism and the image force effect, which is induced by an image charge in the metal.

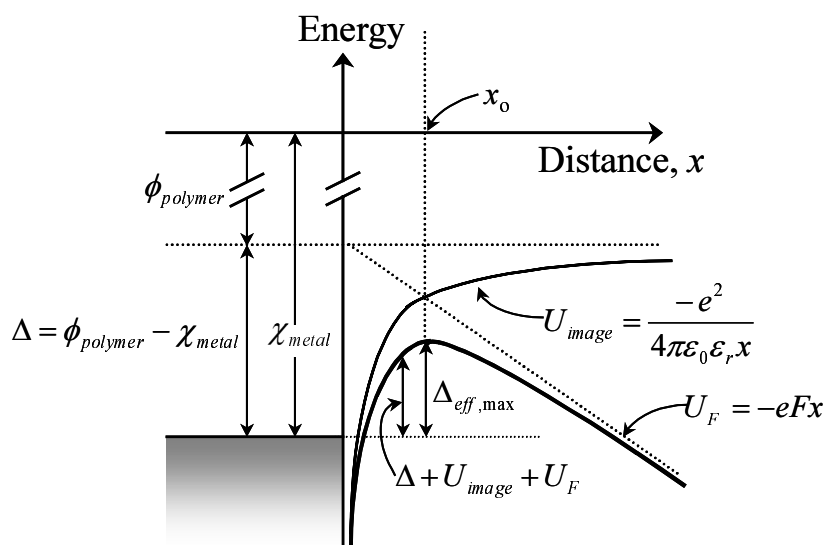

Figure 8. Schematic energy diagram to illustrate thermally assisted carrier injection of an electron into the over an-image lowered energy barrier, and into the LUMO of an organic semiconductor. $\phi_{polymer}$ is the LUMO level of the polymer, χ is the workfunction of the metal, x is the distance into the organic material from the metal/semiconductor interface, ϵ_0 is the permittivity of free space, ϵ_r is the relative permittivity of the semiconductor, e is the unit of electrical charge, F is the applied field, and U is the potential. x_0 is the distance from the metal, at which the barrier height is a maximum, $\Delta_{eff,max}$.

We will return to the issue of contact injection in more details and we will only mention here that the formalism that derives from Figure 8 has some assumptions and limitations but is nevertheless widely used and proves useful. In the context of organic semiconductor we mention two possible limitations that we will expand upon at a later stage: a) the contact material may be a semiconductor or a lightly doped polymer which are not of metallic nature - image force is not applicable. b) The device size is typically 100nm or less so that x_0 in Figure 8 might not be negligible.

Transport and current voltage relation

There are many levels through which one can approach transport in organic materials. This is mainly dependent upon the depth of the physical picture one employs. In the first approximation these are wide bandgap undoped semiconductors. In this case one expects to be able to apply the formalism of space charge limited current that was developed for semi-insulating materials. In this case we assume that it is possible to inject charge carriers at a density higher than the thermally generated ones. This is relatively easy in undoped widegap materials but can also occur in intrinsic InGaAs at high current injection levels found in PIN laser structures. We also assume single carrier injection (hole only or electron only device) and that the mobility neither field nor density dependent.

The physical picture is as follows. At low injection levels the existing charge carriers (due to ionised impurities) are sufficient to carry the current and there is no need to enhance the charge density in the device to support such currents. In this case the current flow is ohmic in nature. At higher injection levels the existing charge density (which is compensated by the relevant ion) is not sufficient and the charge density in the device rises above the thermal value. Since the extra-injected charges are not compensated by ions (or other opposite charge) an absolute charge density is created. Namely the device is charged and a space charge is formed. The relevant equations are summarised below.

$$J = Ne\mu E(x) - De \frac{\partial}{\partial x} N \quad \text{Continuity eq.}$$

$$\frac{\partial}{\partial x} E(x) = \frac{e}{\epsilon} N(x) \quad \text{Poisson eq.}$$

Neglecting diffusion currents:

$$J = Ne\mu E(x) \quad \text{Ohmic current}$$

Substitute N

$$J = \epsilon\mu E(x) \frac{\partial}{\partial x} E(x)$$

Integrate

$$J \int_0^x d\xi = \epsilon\mu \int_0^x E(\xi) \frac{\partial E(\xi)}{\partial \xi} d\xi$$

$$Jx + K = \frac{1}{2} \epsilon\mu E(x)^2 \quad (- \sim D \frac{d}{dx} E)$$

K is integration constant

$$E(x) = \sqrt{\frac{2J}{\epsilon\mu} (x + K)}$$

$$\text{Boundary at contacts: } \left. \frac{\partial}{\partial x} E \right|_{x=0} = \frac{N_0 e}{\epsilon} \quad (N_0 \approx 10^{21} \exp\left(-\frac{\Delta\Phi}{kT}\right))$$

$$\rightarrow K = \frac{J\epsilon}{2N_0^2 e^2 \mu}$$

For device of thickness d

$$V = \int_0^d E(x) dx = \sqrt{\frac{8J}{9\epsilon\mu}} \left\{ (d + K)^{3/2} - K^{3/2} \right\}$$

for $K \ll d$

$$J_{SCL} = \frac{9}{8} \epsilon\mu \frac{V^2}{d^3} \quad \text{"Purely" Space Charge Limited regime}$$

for $K \gg d$

$$J_{ohm} = N_0 e\mu \frac{V}{d} \quad \text{Ohmic conduction}$$

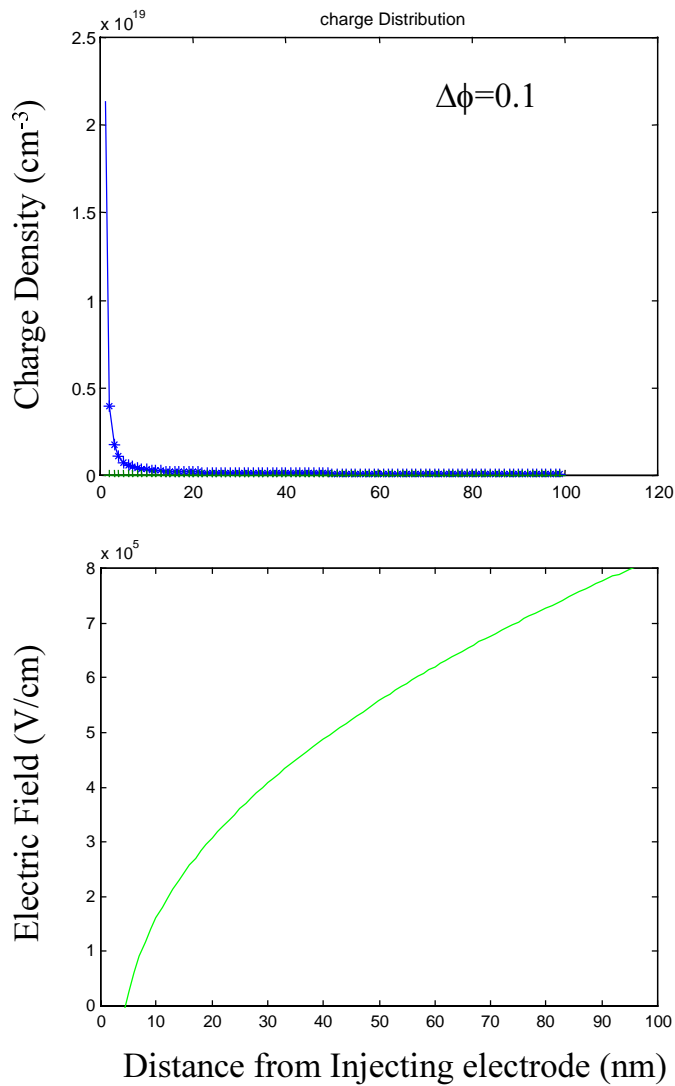

Figure 9. Charge and field distribution for a low contact barrier of 0.1eV (N_0 is large and K is small). $V-V_{bi}=5V$

For the SCL case we find that the maximum field is $E(L) = \sqrt{\frac{2j}{\epsilon\epsilon_0\mu}} L$. Comparing this to the rearranged expression for SCL current $\frac{V}{L} = \sqrt{\frac{8j}{9\epsilon\epsilon_0\mu}} L$ we find that at the ideal case $E(L) = 1.5 \frac{V}{L}$. In a real device (as in Figure 9) the field near the contact is even negative thus making $E(L)$ even larger (to make sure V stays the same).

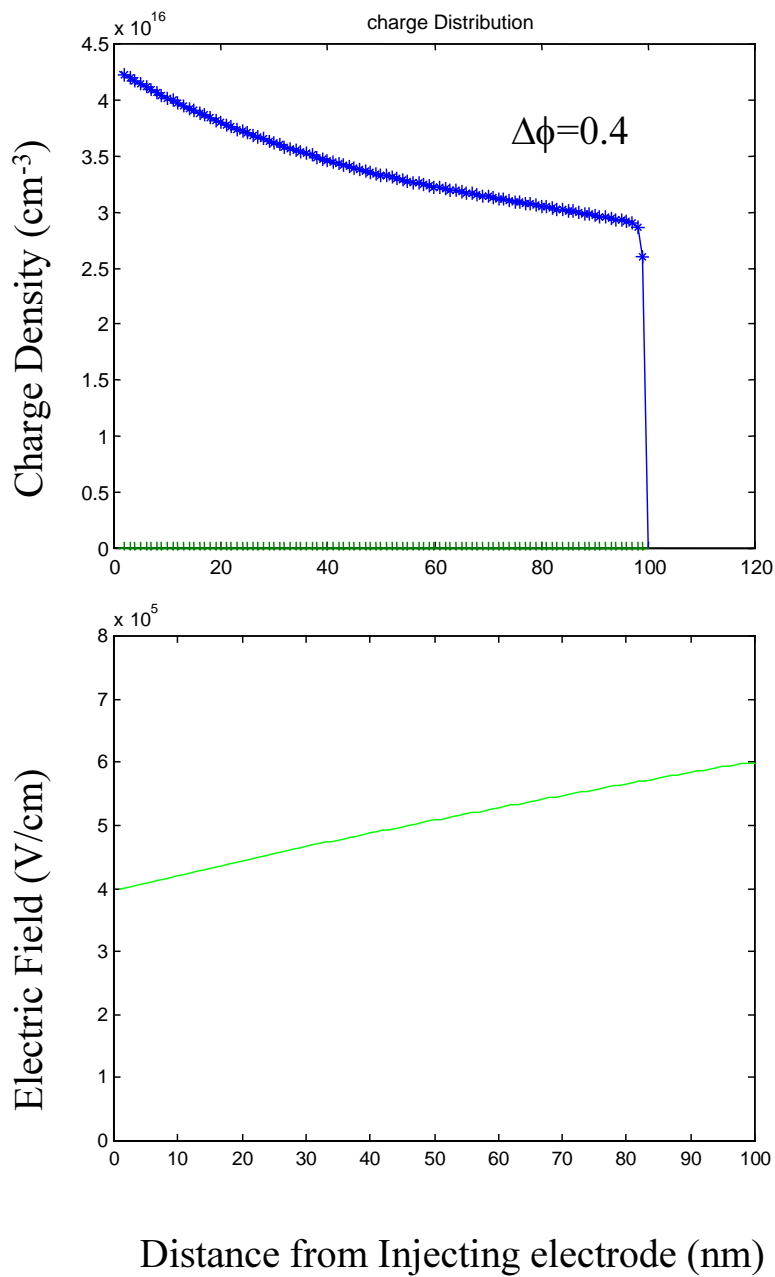

Figure 10. Charge and field distribution for a low contact barrier of 0.4eV (N_0 is small and K is large). Note that the charge and field distribution tends to be uniform as is ohmic conduction. $V-V_{bi}=5V$

Bulk Limited injection or ohmic contact

As we have seen:

$$E(z) = \sqrt{\frac{2j}{\varepsilon\varepsilon_0\mu} \left(z + \frac{j\varepsilon\varepsilon_0}{2N_{\text{Contact}}^2 q^2 \mu} \right)}$$

Here j is the current density, N_{Contact} is the density near the contacts and the rest have their common meaning. In a classic SCL current model the second term is neglected

and then $j_{\text{SCL}} = \frac{9V^2}{8L^3} \varepsilon\varepsilon_0\mu$.

$$N_0 \approx 10^{21} \exp\left(-\frac{\Delta\Phi}{kT}\right)$$

$$K \ll L \rightarrow \frac{J\varepsilon}{2q^2\mu} \ll L \left\{ 10^{21} \exp\left(-\frac{\Delta\Phi}{kT}\right) \right\}^2$$

$$\frac{9V^2\varepsilon^2}{16L^4q^2} \ll \left\{ 10^{21} \exp\left(-\frac{\Delta\Phi}{kT}\right) \right\}^2$$

$$\text{For } V=10\text{V}; L=100\text{nm}; kT=0.026 \rightarrow \boxed{\Delta\Phi < 0.3\text{eV}}$$

So we find that for barriers below 0.3eV the conduction is bulk limited. If we account also for image force lowering of the barrier that the limit is closer to 0.4eV. In any case it is bias dependent.

Overall charge in the device

$$\frac{\partial}{\partial x} E(x) = \frac{e}{\varepsilon} N(x)$$

$$E(x) = \sqrt{\frac{2J}{\varepsilon\mu}} (x + K)$$

$$\int_0^d N(x) dx = \frac{\varepsilon}{e} \int_0^d \frac{\partial E}{\partial x} dx = \frac{\varepsilon}{e} \sqrt{\frac{2J}{\varepsilon\mu}} \left\{ (d + K)^{1/2} - K^{1/2} \right\}$$

$K \ll d$

$$\int_0^d N(x) dx = \frac{\varepsilon}{e} \sqrt{\frac{2J}{\varepsilon\mu}} d^{1/2} = \frac{3}{2} \left(\frac{\varepsilon V}{ed} \right)$$

and the average density is:

$$\bar{N} = \frac{1}{d} \int_0^d N(x) dx = \frac{3}{2} \left(\frac{\varepsilon V}{ed^2} \right)$$

$$Q = \bar{N} * d * e = \frac{3}{2} \frac{\varepsilon}{d} V = \frac{3}{2} C_0 V$$

→ Capacitance of SCL device is 1.5 time the geometrical one.

Transitions**Ohmic to SCL**

At low currents the thermal density (N_T) is sufficient:

$$J_{ohm} = N_T e \mu \frac{V}{d} \quad \text{Ohmic conduction}$$

at high currents we arrive at SCL"

$$J_{SCL} = \frac{9}{8} \epsilon \mu \frac{V^2}{d^3} \quad \text{"Purely" Space Charge Limited regime}$$

At the cross-over point:

$$V_{\Omega} = \frac{8 e N_T d^2}{9 \epsilon}$$

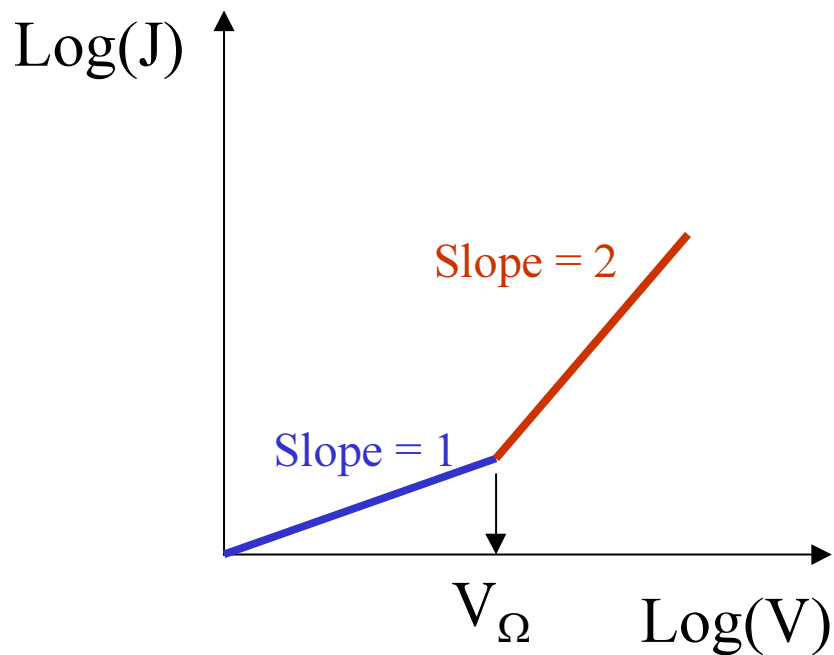

Figure 11. Schematic description of an IV curve

From V_{Ω} one can find the thermal charge density or the ionised impurity density.

References

- [1] H. Sirringhaus, P. J. Brown, R. H. Friend, M. M. Nielsen, K. Bechgaard, B. M. W. Langeveldvoss, A. J. H. Spiering, R. A. J. Janssen, E. W. Meijer, P. Herwig, and D. M. deleeuw, "Two-dimensional charge transport in self-organized, high-mobility conjugated polymers," *Nature*, vol. 401, pp. 685-688, 1999.
- [2] R. Osterbacka, C. P. An, X. M. Jiang, and Z. V. Vardeny, "Two-dimensional electronic excitations in self-assembled conjugated polymer nanocrystals," *Science*, vol. 287, pp. 839-842, 2000.
- [3] C. Adachi, T. Tsutsui, and S. Saito, "Confinement of charge carriers and molecular excitons within 5-nm-thick emitter layer in organic electroluminescent devices with a double heterostructure," *Appl. Phys. Lett.*, vol. 57, pp. 531-533, 1990.
- [4] A. R. Brown, J. H. Burroughes, N. Greenham, R. H. Friend, D. D. C. Bradley, P. L. Burn, A. Kraft, and A. B. Holmes, "Poly(p-phenylene vinylene) Light-Emitting Diodes: Enhanced Electroluminescence Efficiency Through Charge Carrier Confinement," *Appl. Phys. Lett.*, vol. 61, pp. 2793-2795, 1992.
- [5] A. Dodabalapur, L. J. Rothberg, R. H. Jordan, T. M. Miller, R. E. Slusher, and J. M. Phillips, "Physics and applications of organic microcavity light emitting diodes," *J. Appl. Phys.*, vol. 80, pp. 6954-6964, 1996.
- [6] C. W. Tang and S. A. VanSlyke, "Organic Electroluminescent Diodes," *Appl. Phys. Lett.*, vol. 51, pp. 913-915, 1987.
- [7] J. J. M. Halls, K. Pichler, R. H. Friend, S. C. Moratti, and A. B. Holmes, "Exciton diffusion and dissociation in a poly(p-phenylenevinylene)/c-60 heterojunction photovoltaic cell," *Appl. Phys. Lett.*, vol. 68, pp. 3120-3122, 1996.
- [8] J. Halls, J. Cornil, D. dos Santos, R. Silbey, D. Hwang, A. Holmes, J. Bredas, and R. Friend, "Charge- and energy-transfer processes at polymer/polymer interfaces: A joint experimental and theoretical study," *Phys Rev B*, vol. 60, pp. 5721-5727, 1999.
- [9] J. L. Brédas, *Personal Communication*.

- [10] L. J. Rothberg, M. Yan, F. Papadimitrakopoulos, M. E. Galvin, E. W. Kwock, and T. M. Miller, "Photophysics of phenylenevinylene polymers," *Synth. Met.*, vol. 80, pp. 41-58, 1996.
- [11] A. D. Yoffe, "LOW-DIMENSIONAL SYSTEMS - QUANTUM-SIZE EFFECTS AND ELECTRONIC-PROPERTIES OF SEMICONDUCTOR MICROCRYSTALLITES (ZERO-DIMENSIONAL SYSTEMS) AND SOME QUASI-2-DIMENSIONAL," *Adv. Phys.*, vol. 42, pp. 173-266, 1993.
- [12] M. Knupfer, E. Zojer, G. Leising, and J. Fink, "The size of electron-hole pairs in pi-conjugated oligomers," *Synth. Met.*, vol. 119, pp. 499-502, 2001.